



Backyard Burning in Urban Areas

The North Perth Fire Department, By-law Enforcement Staff, as well as the OPP, receive and respond to many calls and concerns related to backyard burning in residential areas, particularly in the spring and summer months.

Reference the information in this handout to ensure your backyard burning activities comply with the Burn By-law, as well as learn the proper steps to register a complaint. Our by-law may change - we encourage you to check the by-law on our website each year to ensure you are in compliance.

Municipality of North Perth

Burn By-law: Urban Burn Requirements and Complaint Reporting



This handout is for public convenience and summarizes key parts of the Burn By-law No. 117-PW-2001 related to open burning/fires in the municipality. This is not a legal document. A certified copy of the original by-law should be consulted for all interpretations/ applications of the by-law. All fees listed and bylaws are subject to change and amendments.

By-law Requirements for Urban Areas

- No open burning shall be permitted
- Occupants of urban areas must use an **approved containment site** as shown in Appendix C of the by-law (i.e. drum, truck, or car rim) - see examples below
- The containment site must be a safe distance of **approx. 25 feet** from any building or combustible material
- Burning must be **attended by a responsible person** suited for the task

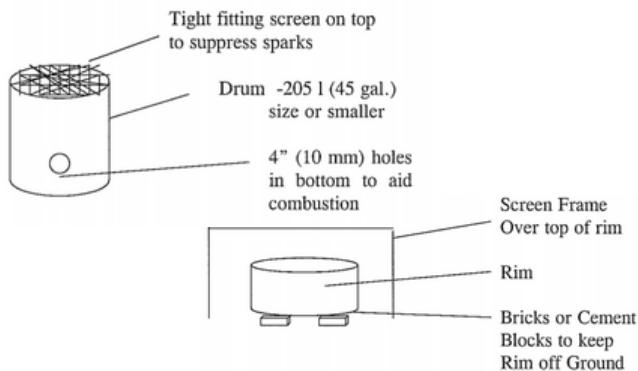

Additional Requirements for Approved Contained Fires

- Contained fires are permitted for cooking purposes only
- Burning containers in good repair
- No burning on windy days
- No burning that contains rubber and/or plastics or household garbage or material that produces obnoxious odours to the surrounding neighbourhood or violates the requirements of the Ministry of Environment, Air Quality Branch or any other Provincial/Federal legislation
- Supervised at all times by a responsible person suited for the task
- Minimum of 20 litres or 5 gallons of water available near the site
- Recyclable material must not be burned
- No burning is allowed if smoke conflicts with any neighbours

How is the impact on neighbours measured?

When responding to a burning complaint, Fire Department personnel, By-law Enforcement Officers and/or the OPP will observe the circumstances of the situation to determine if smoke is conflicting with neighbouring properties. In most cases, the host of the fire will be asked to extinguish the fire and not have another fire for the remainder of the day/evening.





Fire Department Response

Anyone who sets a fire in the open air without permission or without adhering to the conditions set out in the Burn By-law and requires the attendance of the Fire Department will be responsible for the cost of dispatching fire equipment to the site and for bringing the said fire under control. This will include vehicle and workforce costs or other firefighting costs that may occur.

Complaint Procedure

If you would like to make a complaint regarding backyard burning, please follow the complaint procedures outlined below.

It is important that complaints are received while the incident is occurring and by the proper authorities. This allows issues to be addressed in an appropriate and timely manner, as well as charges laid where necessary.

If the burn is occurring during regular municipal office hours:

Report your complaint to the **North Perth Fire Department by calling 519-291-6825.** North Perth Fire Department personnel will respond to the property of concern.

If the burn is occurring outside of regular municipal office hours:

Report your complaint to the **OPP Non-Emergency Line by calling 1-888-310-1122.** An OPP officer will be dispatched to the property of concern.

In order for the Fire Department or OPP to lay a charge under the By-law, a victim must be identified. Therefore, a complainant is required to provide their name to the authorities.

Burn Permits



If you are planning an open burn in a **rural area** that will be larger than 3 metres (10 ft) in diameter, you must receive a burn permit before you begin.

Contact the North Perth Fire Department Administration Office during operating hours (Monday-Friday, 8:30 AM-4:30 PM) to request a Burn Permit. Leaving a voice message does not constitute permission for an open burn.

Municipal By-laws

You can view the full North Perth Burn By-law No. 117-PW-2001, as well as other municipal by-laws, by visiting the North Perth Municipal website: <https://www.northperth.ca/bylaws/>



Municipal Contact Information

If you have questions about the North Perth Burn By-law or information in this brochure, please contact us.

North Perth By-law Enforcement

- Address: 330 Wallace Ave. N., Listowel
- Phone: 519-291-2950 or 519-292-1448
- Email: nalexander@northperth.ca or mboyle@northperth.ca

North Perth Fire Department

- Address: 620 Wallace Ave. S., Listowel
- Phone: 519-291-6825
- Email: jbenn@northperth.ca

Municipal Office Hours

Monday-Friday
8:30 AM - 4:30 PM
Closed weekends and statutory holidays

Follow us on social media!

Facebook: @north.perth
Twitter: @NorthPerth1 & @northperthfd
Instagram: @northperth & @northperthfd

